

REPLACEMENT OF ROUTINE MAINTENANCE PARTS

Caution Make sure you unplug the sealer before replacing any parts.

Keep the pressure lever up when you replace parts.
Be careful of cutter blade on PC-200, PC-300. It will be EXPOSED when the lever is up.

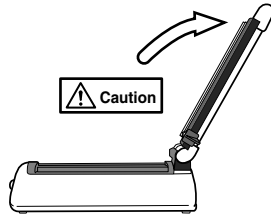

• TEFLON TAPE REPLACEMENT

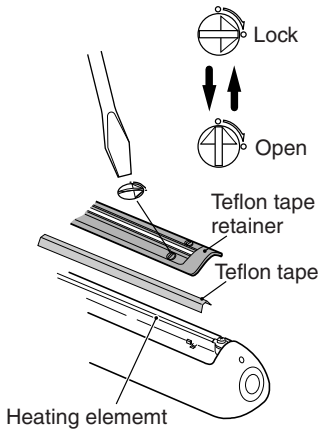

With a minus screwdriver, turn the 4 points (P-300, PC-300 : 6 points) screw slots on the teflon tape retainer 1/4 counterclockwise.
Remove the teflon tape retainer and damaged teflon tape.
Then place the new teflon tape to be centered over the heating element.
Put the teflon tape retainer over it and secure the 4 points (P-300, PC-300 : 6 points) screw slots 1/4 clockwise.

PC-200, PC-300

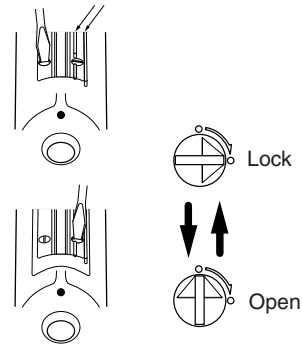

Caution When replacing the parts of PC-200/300, take a sufficient care to the edge of a cutter.

• HEATING ELEMENT REPLACEMENT

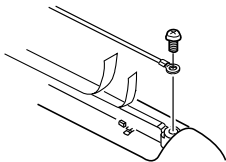

Remove the teflon tape 23, and then the screw 17 take out the heating element.
The glass tape 16 and sarcon sheet 15 are under the heating element and are routine maintenance parts. Replace them when necessary.

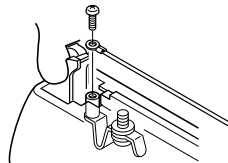

Hook one end of the new heating element to the electrode, and fasten the other end to the frame 13 with the screw 17.

• SILICONE RUBBER REPLACEMENT

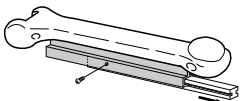

Loosen the screw fastening the silicone rubber 7 to the crimp plate and pull the rubber out.

Caution Be careful of the cutter blade while replacing other components.

REPLACEMENT OF PC-200, PC-300

• CUTTER BLADE REPLACEMENT

Lift the pressure lever 51 and loosen the screw (B tight, phillips round-head 3X8).
Replace the cutter blade 54 with a new one.

