

10 Replacing the routine maintenance parts

Daily maintenance or replacement of parts at an early stage can prevent the machine from being damaged, and keeps the machine at the optimum condition. Replace parts according to the following directions in order to maintain your machine in optimum operating condition.



Always unplug the power plug before replacing parts. There is a danger of electrocution if it has been done without unplugging.



Follow the directions on this manual when replacing parts. Replacing parts in the way ignoring this manual could cause malfunction of the machine as well as electrocution and fire.



Always use only specified parts sold through Fuji Impulse. Unspecified parts may cause malfunction of the machine.



Always unplug the machine before maintenance.

Structure of the sealing section

The sealing section consists of the parts as in the illustration below. When replacing parts, be careful to arrange the parts exactly in the same order.

Single side heating

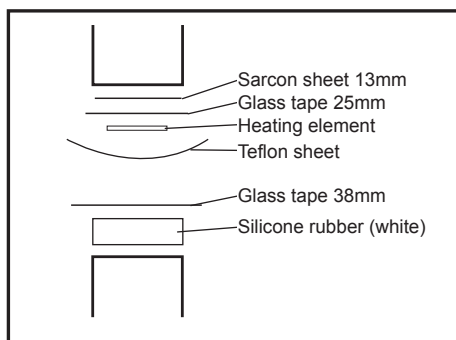

Double side heating

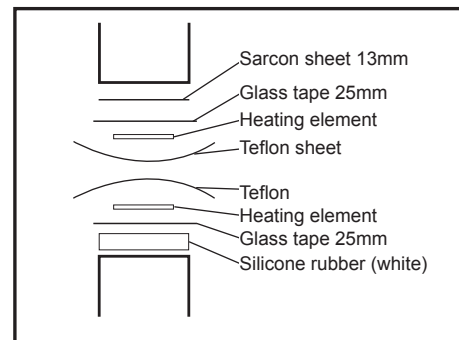

10-1 Preparation

•Before replacing parts...



Before replacing parts, make sure to unplug the power cord.

When the pressure-adjusting nut is removed, the sliding shaft descends and the plunger goes down into the solenoid case. This can activate the microswitch and the heating process may start, which may cause burning especially if you are holding the pressure lever when replacing parts.

How to lift up the pressure lever

- 1 Loosen the pressure-adjusting nut fastening screw.
- 2 Turn the pressure -adjusting nut counterclockwise and remove the nut.
- 3 Lift up the pressure lever.

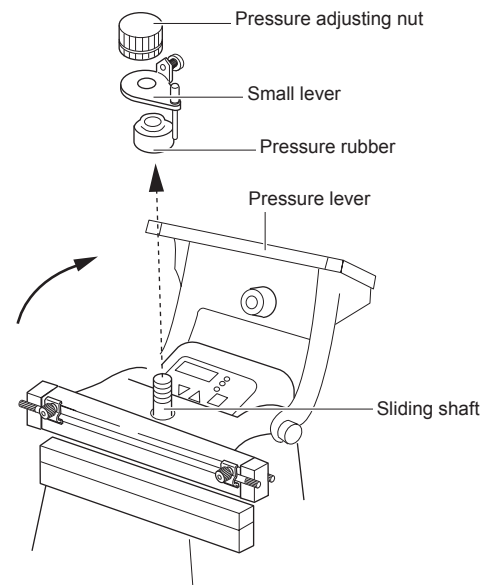

How to install the pressure adjusting Nut

- 1 Insert the sliding shaft into the hole at the pressure lever as in the right illustration.
- 2 Lift up the sliding shaft and push it back against the hole so the shaft does not slip.
- 3 Insert the pressure rubber and small lever to the sliding shaft in the order as in the right illustration. When installing the pressure adjusting nut, please refer to “11-1 Adjusting the Sealing Pressure.”

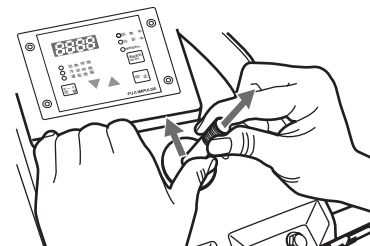

10-2 Sliding the Teflon sheet

Replace when: The Teflon burns, or when the seal becomes messy.

Teflon is either sold individually or included in the maintenance parts kit (only for CA-300 series). It is rolled to the Teflon roll bar about 25 - 30cm as an extra.

- 1 Loosen four plastic nuts (white) and until the Teflon roll bar can be moved.
- 2 Roll up the damaged Teflon to the Teflon roll bar of the either side.
- 3 Tighten the plastic nuts (white) and fix the Teflon roll bar with a Teflon sheet holding plates.

Attention! No wrinkles or slacking is allowed in order to achieve the beautiful, strong seal.

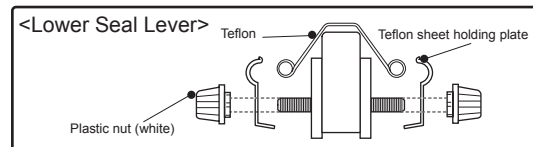
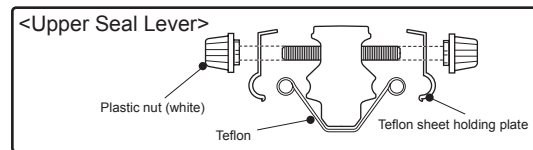
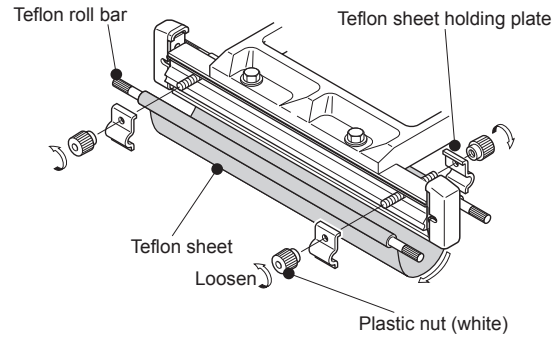

10-3 Replacing Teflon sheet

Essential tools: Cellophane tape (scotch tape)

Replace when: The Teflon burns, or when the seal becomes messy.

- 1 Loosen four plastic nuts (white) and remove the Teflon sheet holding plates and the Teflon roll bars. And then remove the Teflon sheet from the Teflon sheet roll bars.
- 2 Adhere the new Teflon sheet to the Teflon roll bars with scotch tape, etc.
- 3 Install the Teflon roll bar to either pressure lever or seal receiving plate, and temporarily secure it with the four plastic nuts (white).
- 4 Roll up the Teflon roll bar so the Teflon sheet does not get wrinkled.
- 5 Securely tighten the plastic nuts (white) and fix the Teflon roll bar with a Teflon sheet holding plates securely.

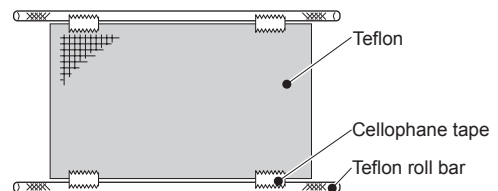

10-4 Replacing the heating element

Essential tools: A Philips screwdriver

Replace when: The heating element breaks, unevenness is generated, or when the seal becomes messy.

- 1** Remove the Teflon sheet referring to “10-3 Replacing the Teflon sheet.”
- 2** Loosen the electrode cover mounting screws and remove electrode covers.
- 3** Lift up the electrode lever downward or upward depending on the upper or lower heating type, and using the Philips screwdriver, loosen the screw that secures the heating element.
- 4** With the electrode lever still lifted insert the new heating element into the electrode groove. Make sure that the heating element stays in place with the electrode as you securely tighten the screw to keep the heating element in place. Return the electrode lever to the initial position. Reattach the electrode covers.

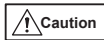
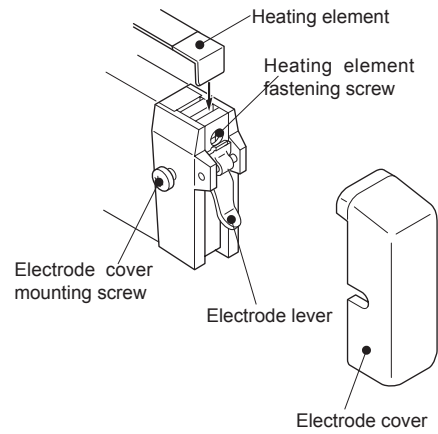

Caution For safety, always attach the electrode cover after replacing the heating element. Always use a Fuji Impulse-designated, special heating element for replacement. Using a heating element other than the designated heating element may cause the transformer to be heat-damaged.

10-5 Replacing the 25mm-width glass tape and Sarcon sheet

Essential tools: Scissors, a Philips screwdriver,
Alcohol (Ethanlo)

Replace when: The heating element breaks often, the
seal becomes messy, etc.

The 25mm-width glass tape and Sarcon sheet are either
sold individually or included in the maintenance parts
kit for Ca-300, CA-300-E(D) series (the glass tape not
included).

- 1 Carefully read the respective replacement
instructions on the Teflon and heating element
and remove all of them.
- 2 Completely remove the glass tape and Sarcon
sheet below the heating element.

Attention! Applying the Sarcon sheet and glass
tape to a surface with adhesive
residues will negatively affect the
sealing surface. Make sure to clean the
residues using alcohol (Ethanol).

- 3 Cut the new Sarcon sheet 2mm longer than the
seal area for left and right sides and adhere it to
the lever.

- 4 Adhere the glass tape over the Sarcon sheet so it
covers the electrode about 5mm on both sides.

Attention! If the adhesive of the Sarcon sheet is
weak when replacing the glass tape,
please replace the Sarcon sheet as
well.

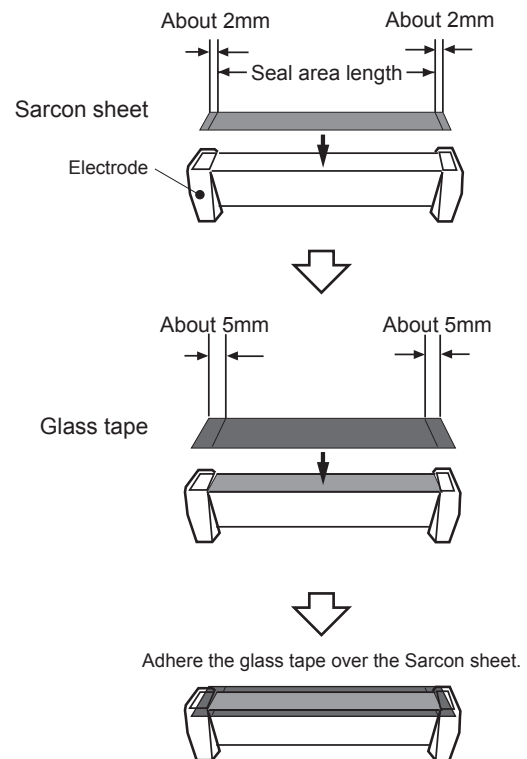

10-6 Replacing the 38mm-width glass tape (For the lower lever of single heating type)

Essential tools: Scissors

Replace when: The heating element breaks often, the seal becomes messy, etc.

38mm-width glass tape is sold individually.

- 1 Remove damaged glass tape on the silicone rubber (white), and completely remove the adhesive residues using alcohol (Ethanol).

Attention! Applying the glass tape to a surface with adhesive residues will negatively affect the sealing surface. Make sure to clean the residues using alcohol.

- 2 Adhere 38mm-width glass tape so it covers the sealing area +2cm extra on both sides.

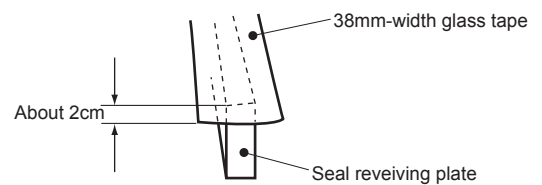

- 3 Fold the excess tape.

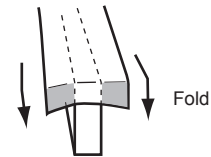

- 4 Fold the glass tape on both sides of the sealing lever as in the right illustration.

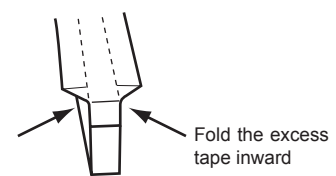

- 5 Fold the glass tape along both edges so that the excess tape over the sealing lever adheres to the sides of the clamping lever.

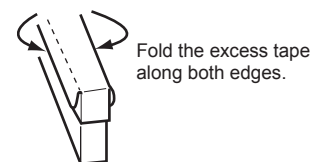

10-7 Replacing the silicone rubber (white)

Essential tools: Alcohol (Ethanol)

Replace when: The seal becomes messy, etc.

The silicone rubber is either sold individually or included in the maintenance parts kit for CA-300 and CA-300W(D).

- 1 Remove damaged glass tape on the silicone rubber (white), and completely remove the adhesive residues using alcohol (ethanol).

- 2 Remove the damaged (old) silicone rubber.

Attention! Applying the silicone rubber to a surface with adhesive residues will negatively affect the sealing surface. Make sure to clean the residues using alcohol.

- 3 Adhere the new silicone rubber (white) starting from the edge.

Attention! Adhere the silicone rubber carefully as it cannot be reapplied.

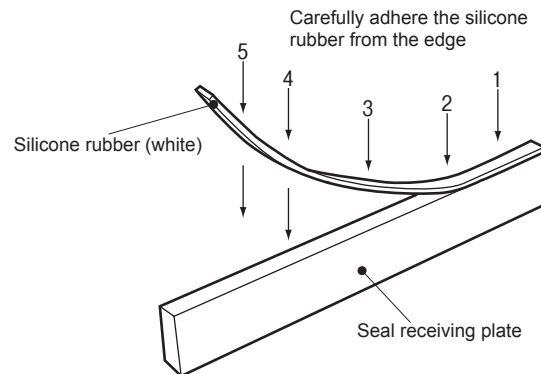

10-8 Replacing the pressure rubber

Essential tools: N/A

Replace when: The height of the shock absorbing clearance become lower than 2mm. (New pressure rubber has 3mm in height.)

The pressure rubber is sold individually.

Periodically inspect the height of shock absorbing clearance.

For the easier replacement, lift up the pressure lever referring to “10 Replacing the routine maintenance parts >>> 10-1 Preparation.”

Warning New pressure rubber has 3mm-high shock absorbing clearance. The long-term use of the machine will cause the wear-out of the pressure rubber. If the shock absorbing clearance become less than 2mm, sealing pressure increases and too much pressure can be applied to the sealing area. This is extremely dangerous especially when a finger is caught in the sealing area by any chance. Inspect the pressure rubber before the operation and replace it if necessary.

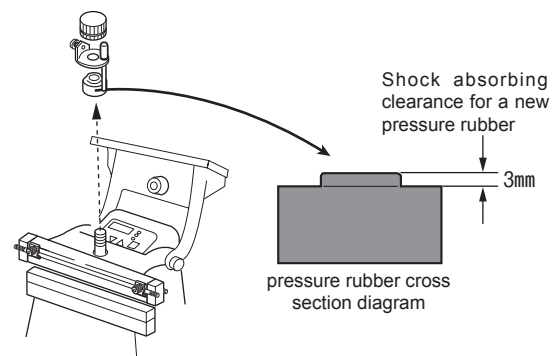

11 Adjusting each part

11-1 Adjusting the seal pressure

Adjust the pressure strength indicated on the seal pressure adjusting nut using the pointer on the small lever.

- 1 Loosen the pressure adjusting nut fastening screw.
- 2 Turn the pressure adjusting nut to adjust the sealing pressure to a level suited for the thickness of the packaging material used. Use the compatible thickness described on the pressure adjusting nut as guidance. (Turn the pressure adjusting nut fully clockwise as it stops at the pressure for less than 0.1mm, then turn counterclockwise to adjust.)
- 3 Once the adjustment is made, always use the securing screw to secure the pressure adjusting nut.

Warning Operating while the nut is turned excessively clockwise (the direction for handling thinner packaging material) may cause sealing failure or cause the pressure lever to remain at the lowered position due to the solenoid suction strength dropping and the microswitch not being activated. In addition, it is very dangerous due to the excessive pressure. Always operate by following the instructions in the following **Attention!** and the setting within the red range described on the label on the adjusting nut.

Warning Operating while the nut is turned excessively counterclockwise (the direction for handling thicker packaging material) will increase the sound of the pressure lever movement.

Attention! What to do if you loosen the pressure adjusting nut too much. In the case you have loosened and caused to remove the pressure adjusting nut at the time of parts replacement:
 Turn the pressure adjusting nut fully clockwise so that it stops at [Less than 0.1mm] scale. Then adjust the pointer on the scale for the packaging material. Normally, operation is done in the [NORMAL] position.

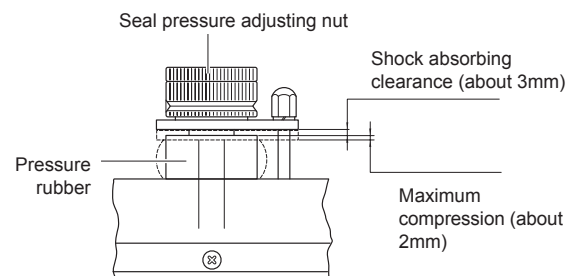
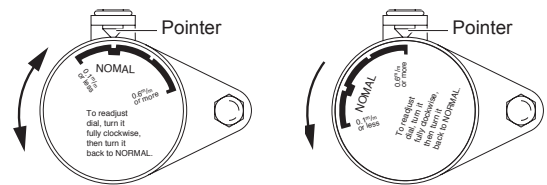
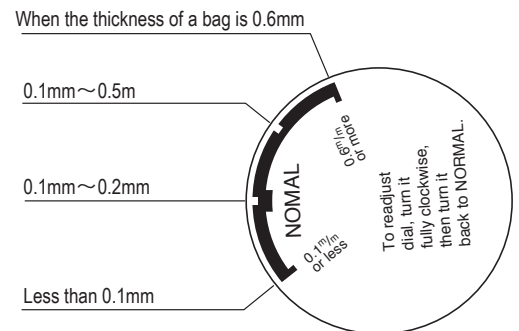
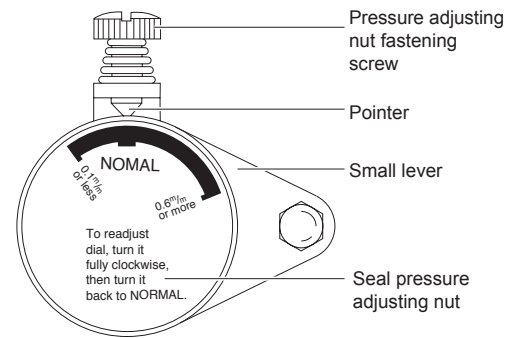

11-2 Table switch plate acuator pressure adjustment (for CA-300 series)

When the bag contents are heavy, the table switch may be turned on immediately and activate the sealer. Adjust the table pressure adjustment screw so the table does not activate the sealer.

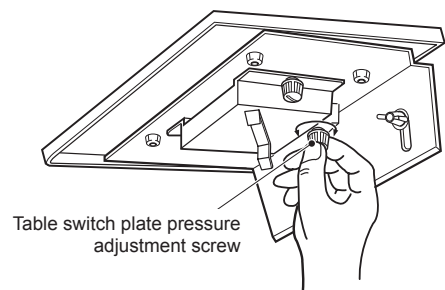

The pressure adjusting spring is installed inside the screw.